

3 PUMP - 3 DUMP SETUP

FRONT PUMP USING 4 SOLENOIDS, REAR PUMP USING 3 SOLENOIDS PER PUMP
TX2RX AUTOMOTIVE WIRELESS SOLUTIONS

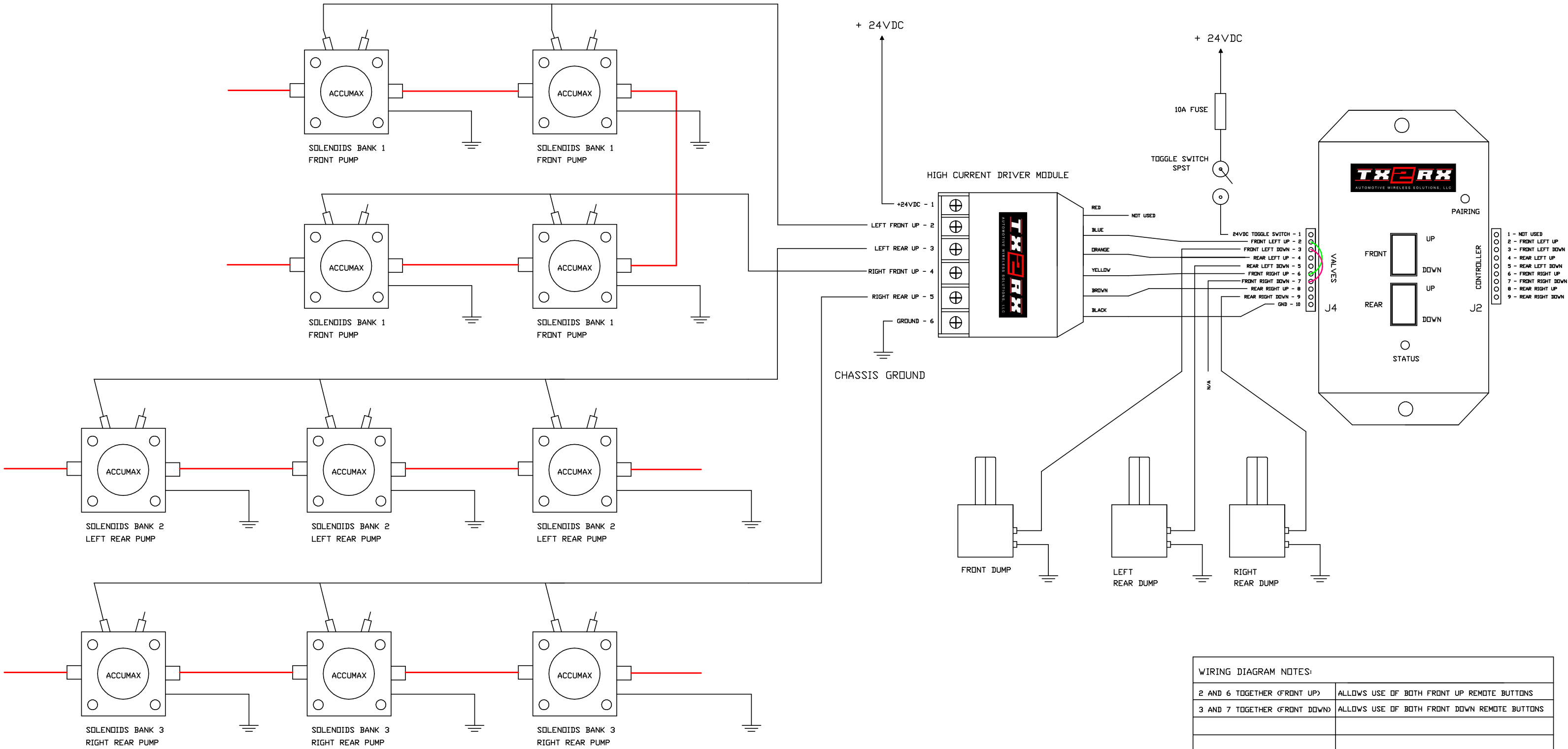

WIRING DIAGRAM NOTES:	
2 AND 6 TOGETHER (FRONT UP)	ALLOWS USE OF BOTH FRONT UP REMOTE BUTTONS
3 AND 7 TOGETHER (FRONT DOWN)	ALLOWS USE OF BOTH FRONT DOWN REMOTE BUTTONS
NOTE * FRONT PUMP SOLENOIDS (4) DIVIDED INTO 2. MAX 3 SOLENOIDS PER CHANNEL	
JUMPER PINS ARE NOT REQUIRED. IT ALLOWS EITHER LEFT OR RIGHT REMOTE BUTTONS TO OPERATE.	